



**C.M. TECHNOLOGY**

Designed and Manufactured in Australia

**FULL DATA SHEET**

**[www.cmtechnology.com.au](http://www.cmtechnology.com.au)**

**Tel: + 61 2 9764 6550**

**PPS12 230v AC to 12 VDC POWER SUPPLY**

**WITH BATTERY MANAGER OPTION**

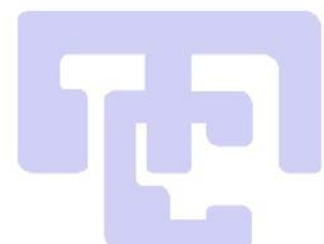

**A Caspian Technology Company**

all materials presented are trade mark and copyright protected by C.M. TECHNOLOGY Pty Ltd



## Table of Contents

<a href="#">Introduction:</a>	3
<a href="#">1.0: Input Voltage:</a>	4
<a href="#">1.1: Mains Hold Up (missing mains cycles):</a>	4
<a href="#">1.2: Mains Input:</a>	4
<a href="#">1.3: Input Transient Protection:</a>	4
<a href="#">1.4: Input Output Isolation:</a>	4
<a href="#">1.5: Other Mains Input Voltages:</a>	5
<a href="#">2.0: Input Voltage:</a>	5
<a href="#">2.1: Factory Set Output Voltage:</a>	5
<a href="#">2.2: Output Regulation (over AC input and D.C load):</a>	5
<a href="#">2.3: Maximum Current:</a>	5
<a href="#">2.4: Efficiency:</a>	5
<a href="#">2.5: Output step response:</a>	5
<a href="#">2.6: Nature of Output Impedance:</a>	6
<a href="#">2.7: Noise and Ripple:</a>	6
<a href="#">2.8: Over Voltage protection:</a>	6
<a href="#">2.9: Isolation to Ground:</a>	6
<a href="#">3.0: Temperature Rating:</a>	7
<a href="#">4.0: Battery Manager (option):</a>	7
<a href="#">4.1: Battery Manager Specification:</a>	7
<a href="#">5.0: Current Sharing:</a>	8
<a href="#">6.0: Physical:</a>	8
<a href="#">7.0: Mechanical:</a>	8
<a href="#">8.0: Approvals:</a>	8

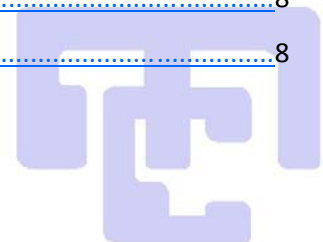



## TYPE 24, 48, 74 & TYPE 110 TELECOMMUNICATION POWER SUPPLIES FOR RAILWAY APPLICATIONS.

### Introduction:

The power supply is designed to mount behind a rack mount front panel using 4 off plastic inserts, OR WITH 4 PLASTIC FEET FOR THE DESKTOP. It is designed to supply 13.8 volts nominal D.C. at 12 amps nominal from a 230 volt 50 to 400 hertz mains source. It uses a thermostatically controlled ball bearing fan to assist cooling. A stand alone desktop model is available

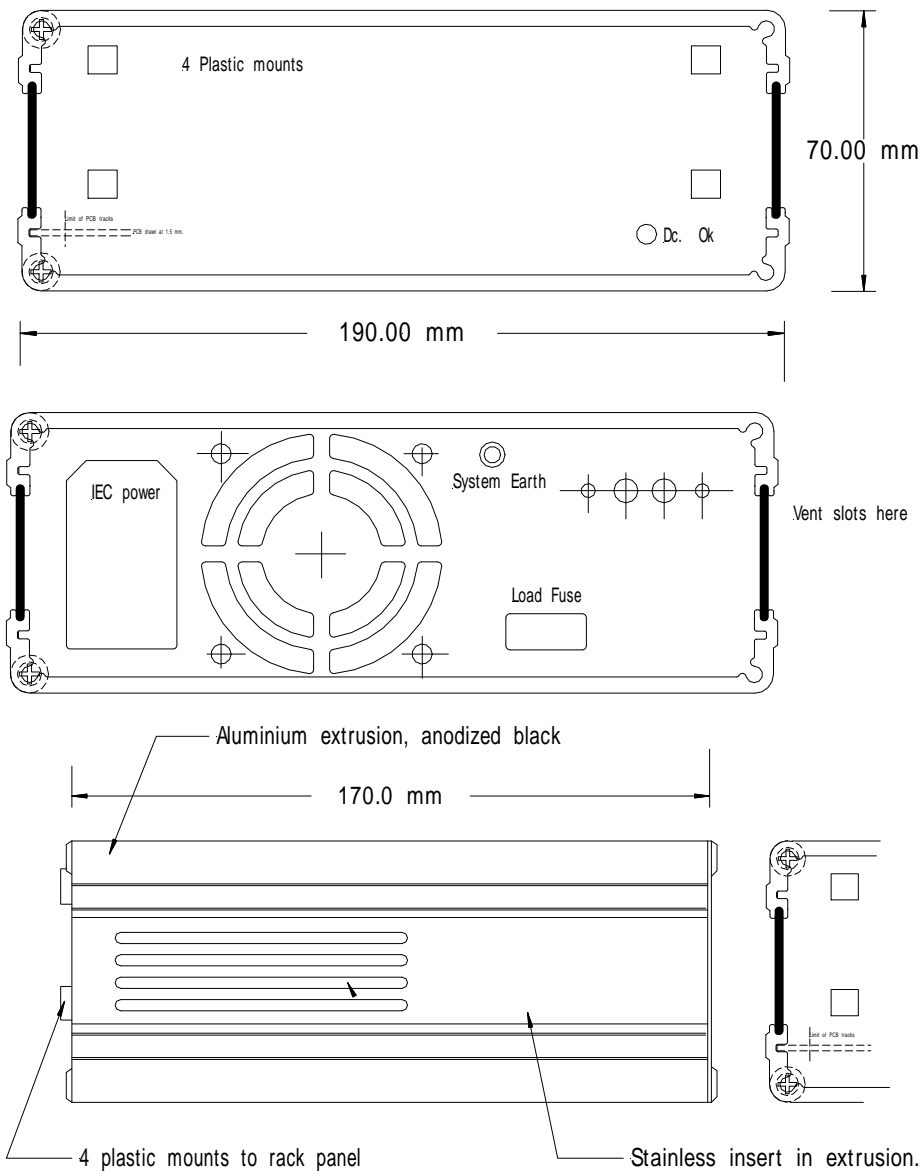

General view of the rack mounts case, showing the brushed stainless steel and extruded construction. The four plastic inserts allow a 10 g self tapper (black and supplied) to mount two to a 2RU front panel. The 5 mm super-bright LED indicates that DC is on. The cooling slots must be kept clear to allow air circulation in the case..

The back view shows the input fused and switched IEC connector. A spare fuse is included in the housing. The output is by means of a JST locking connector. The cooling fan is controlled by a thermostat. The fan and its cooling slots must be kept free of obstruction. A 4mm case earth bolt is included for a system earth if needed.





## 1.0: Input Voltage:

The input voltage is 230 V AC at 50-Hertz nominal. No auto ranging occurs, and the output degrades gracefully below the minimum A.C. input voltage. The maximum voltage is an absolute, determined by the main electrolytics voltage rating.

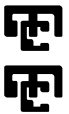

Voltage range (for full specification)	180 V A.C. min (175 typical)	280 V A.C. max
Input Frequency range	D.C. to 400 Hertz.	

### 1.1: Mains Hold Up (missing mains cycles):

The mains hold up at 240 Volts nominal and 50-Hertz and 12 amps load is shown below.

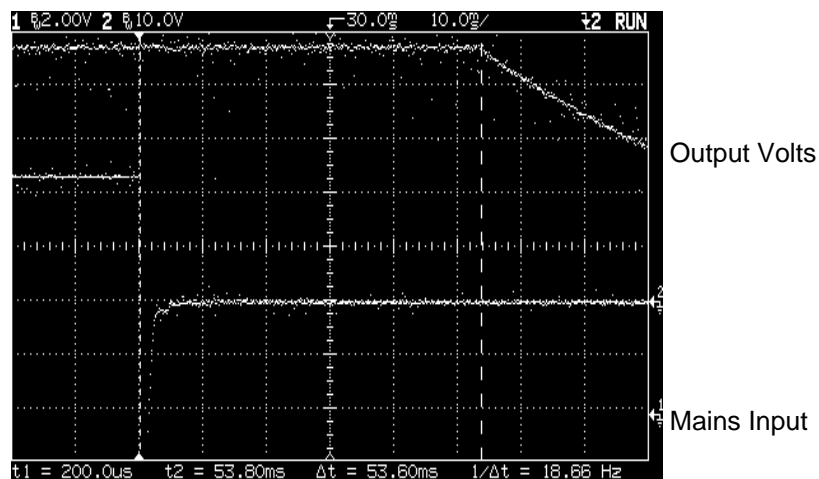

This shows in excess of 50 ms hold up at full rated load.

### 1.2: Mains Input:

The mains input socket is an IEC fused input, UL recognised and CSA certified. A spare fuse is included in the socket.

### 1.3: Input Transient Protection:

The input is protected by three 10 mm-Metal Oxide Varistors, Active to Neutral, Active & Neutral to Earth.

### 1.4: Input Output Isolation:

The supply is a transformer isolated current mode forward converter. The main transformer is designed and factory tested at 3000 VAC. The feedback path is via optical isolators UL rated at 5000 V DC, and the mains to output PCB clearance is 6 mm minimum. The PCB is from a UL certified supplier and is stamped as such.



**C.M. TECHNOLOGY**

Designed and Manufactured in Australia

[www.cmtechnology.com.au](http://www.cmtechnology.com.au)

**FULL DATA SHEET**

**Tel: + 61 2 9764 6550**

### 1.5: Other Mains Input Voltages:

A 110 Volt (nominal) model with full UL certification is available.

### 2.0: Input Voltage:

The voltage and current ratings and regulation are held over the full AC input range.

### 2.1: Factory Set Output Voltage:

The output voltage is factory set by a 20 turn internal preset. The preset can be set without removing the case.



Output Voltage 13.80 volts at 1.0 amp

### 2.2: Output Regulation (over AC input and D.C load):

The output drops < 200mV from 0 to 11 amps load, 230 +/-10% input.

### 2.3: Maximum Current:

The maximum load current is 12 amps. The current limit is >13 amps. The supply can be shorted out. No minimum load current is required. A 15-amp automotive blade fuse is fitted in series with the load terminals.

### 2.4: Efficiency:

The efficiency measured at 230 Volts AC input, 11 amps DC output is: 85% typical

### 2.5: Output step response:

The two oscilloscope images show the current step response (230 VAC nominal input) for a 1 to 11-amp step,

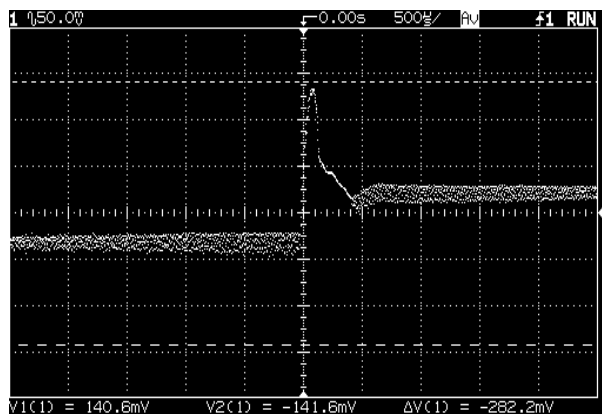

The step response shows a < 150 mV over shoot and is well damped.

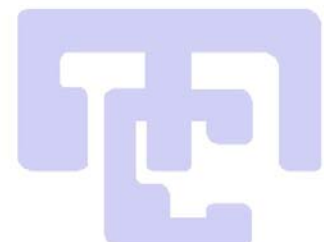

**A Caspian Technology Company**

all materials presented are trade mark and copyright protected by C.M. TECHNOLOGY Pty Ltd



## 2.6: Nature of Output Impedance:

The very low frequency output impedance is represented by the regulation of the supply. At audio frequency the step response above represents it. At the switching frequency, a Nippon Chemi-Con 105 °C Capacitor controls the output impedance. At RF a multilayer monolithic ceramic capacitor is used directly at the output terminals.

## 2.7: Noise and Ripple:

This is about the most difficult thing to measure with a switching power supply. This is because there are always short range circulating magnetic fields near such a supply, ready to inject noise into the high impedance CRO leads of the unwary.

To reproduce the results below, the earth lead and probe tip were removed, and small wire loops screwed into the output terminals A 12 amp load was applied. The left hand one is with the CRO synchronised to the mains input. The right one is locked to the switching frequency.



The ripple and noise is <25 mV rms in a bandwidth of 150 Mhz.

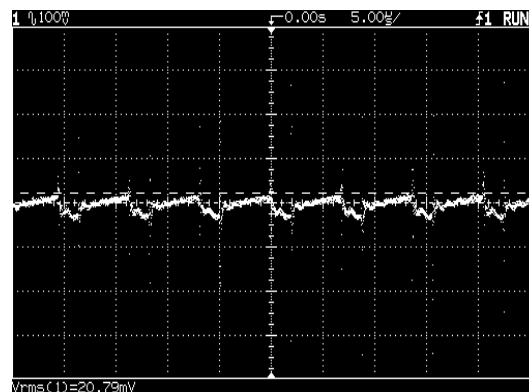
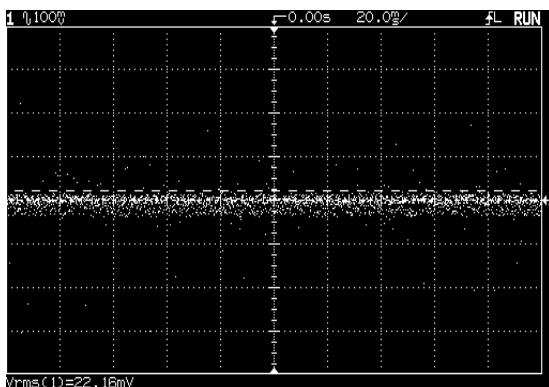

## : 2.8: Over Voltage protection:

The supply uses a completely independent voltage reference to monitor the output voltage. Should this exceed 16 volts, the converter oscillator is shut down via an independent optical isolator. This makes the supply "hiccup". If the fault is an output-induced transient that clears itself, the supply starts up automatically.

## : 2.9: Isolation to Ground:

The supply is DC isolated from the case, but RF bypassed with 1UF ceramic capacitors to ground on both rails. These have a 50 V DC rating.

The input voltage is 240 V AC at 50-Hertz nominal. No auto ranging occurs, and the output degrades gracefully below the minimum A.C. input voltage. The maximum voltage is an absolute, determined by the main electrolytics voltage rating.

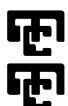

Voltage range (for full specification)	180 V A.C. min (175 typical)	280 V A.C. max
Input Frequency range	D.C. to 400 Hertz.	



### 3.0: Temperature Rating:

Only well specified parts are used from quality suppliers. The supply is designed with 105 °C rated capacitors from Nippon Chemi-Con. Only 1% metal oxide resistors are used. All semiconductors are sourced from Japan, Europe or America.

The fan assist operates on a nominal case temperature of 45 °C, so that at a 20 °C ambient, and 11 amps load, the fan cycles about 25 % of the time. If the ambient exceeds 40 °C, the fan runs all the time. The worst case rise is around 25 °C, so the electrolytics are well within rating, up to an ambient of 60°C.

### 4.0: Battery Manager (option):

As an option to the normal PPS12 power supply, a 1.4 amp battery charger circuit can be included, with a complete battery manager to monitor the battery voltage and disconnect it at 10.5 volts to stop deep discharge. The maximum PPS12 output current is still 12 amps. The total current limit is 14 amps including the maximum of 1.4 amps to the battery.

#### 4.1: Battery Manager Specification:

The Battery Manager was designed to manage a 6 Ah or larger S.L.A. type battery that is typically found in alarm systems as a backup battery. The battery must be rated for a >1.5 Amp inrush. (eg Panasonic type LCR 12V6.5P.) Any battery of larger capacity than this can be used, but the charge current is fixed at around 1.4 amps maximum.

As an example, a Panasonic 12V24P battery would give around 2 hours operation at 8 amps in backup when fully charged at 20 Celsius. It would take around 24 hours to re-charge. The terminal voltage is limited to about 13.9 volts in this mode.

#### (Charge Current and Volts)

The battery terminals are charged at a maximum current determined by an internal resistor and a PTC. Typical Charge current is 1.4 amps at a battery voltage of 12 V

The maximum battery voltage is limited to 13.9 volts at no load.

#### (Under Voltage Lockout)

In battery backup mode, the battery is connected by a Schottky diode to the load. To prevent deep discharge, an internal MOSFET switch disconnects the battery negative rail at ~10.5 volts. The battery is re-connected at 12 volts when the mains return. This hysteresis stops the disconnect circuit hunting as the battery recovers



Under voltage lockout	10.5 volts typical.
Hysteresis	1.5 volts typical

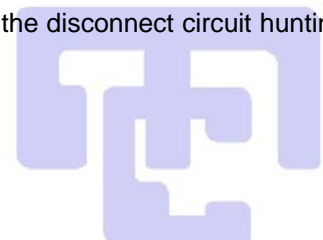



### (Reverse Polarity)

The load is protected against a reverse battery connection with a power MOSFET.

### (Battery FUSE)

A 15 amp automotive blade fuse is on the back panel to protect the PS812 against battery short circuits.

## 5.0: Current Sharing:

The PPS12 is a current mode supply. If the output voltages of two or more supplies are set to the same figure, then they will current share up to 80% of the total allowed load. For example, two supplies connected together will supply up to 20 Amps to a common load.

## 6.0: Physical:

The PPS12 has four output terminals, Battery plus and minus (option) , Load plus and minus. Two supplies can mount on a single 2 RU panel if needed (Optional).

Height:	70mm
Width:	190 mm
Depth	170 mm

## 7.0: Mechanical:

The case has a top and baseplate of 4mm custom extruded aluminium, anodised black. The front and back plates are of 1mm brushed stainless steel and carry 4 mounting inserts on the front plate for rack mounting on a 2 RU (88mm) minimum plate. Two supplies can be mounted side by side in the middle of the rack plate, with a 30 mm clearance between them. The back plate carries the output screw terminals, a fused and switched IEC input, and the thermostat controlled cooling fan. There is also a system earthing bolt. The side plates are 1mm brushed stainless, slotted for cooling purposes. It weighs approximately 1Kg.

## 8.0: Approvals:

The PPS12 carries the Australian Ctick Mark. ***The PPS12 (110) has been tested and certified by the Underwriters Laboratory (UL) and carries the UL marks for the U.S.A. and Canada***  ***The PPS12 (230) will be certified shortly and carry the CE mark for the common market.***